

▶ *projectiondesign*®



▶ *projectiondesign*® **F3+**

SXGA+ (1400x1050)
XGA (1024x768)

| DLP™ Technology

| 6500 ANSI lumens
5500 ANSI lumens

| 7500:1 contrast ratio

| 6000 hours lamp life

| 6 lens options

**The world's most powerful projector
– projectiondesign F3+**

The projectiondesign F3+ is the world's most powerful single chip DLP™ projector. It has been designed to meet the ever increasing requirements in professional imaging solutions, such as public displays, medical imaging, control rooms and visualization and simulation solutions. Utilising DLP™ technology, the F3+ SXGA+ features 1400 x 1050 pixel resolution, and fully configurable brightness at up to 6500 ANSI lumens, creating the world's most powerful single chip DLP™ projector.

The F3+ XGA (1024 x 768) is a cost effective model, based on the high end F3+ SXGA+. It is primarily targeted at rental and staging applications, as well as high intensity 24/7 installations.



High Resolution DLP™ technology

1400 x 1050 pixel resolution provides the most detailed images of any DLP™ projector available. Ideal for visualisation, simulation and medical imaging, the F3+ easily resolves the finer detail of specialty graphics, such as X-Ray and MR, CAD/CAM and design, and for instance oil and gas reservoir 3D modelling and visualisation.

The F3+ provides very high visual resolution display for immersive simulation. Compared to XGA resolution, SXGA+ provides almost double the amount of pixels for a truly seamless image. With support for 1600x1200 and even higher resolutions the F3+ becomes near "resolution less", and as close to a continuous analogue image as possible.

The F3+ XGA with its 1024 x 768 resolution provides a very versatile high performance DLP™ projector. Ideal for rental and staging, video and public displays, the F3+ XGA easily copes with showing high brightness, and great detail. Utilising DLP™ technology gives perfect balance between high performance and affordable price.

24/7 continuous operation

The F3+ is built to operate in heavy duty and continuously run applications, such as control rooms and public displays. Using DLP™ technology – known for its long term stability and reliability – the F3+'s patented DuArch™ architecture features dual lamps, dual colour wheels, and dual light formatters. This lowers wear on each individual component by reducing heat and mechanical wear. In addition, cooling and mechanical design is built to very high standards, with over-specified fans for complete control.



Super long lamp life – 8000 hours

The standard lamps delivered can be set to operate in automatic relay eco mode for a super long life of up to 8000 hours. Run continuously, this setup runs nearly a year before lamps need replacement. The result is a very low cost of ownership, perfect for control rooms and other critical installations.

Dual, single and automatic lamp relay modes

The F3+ can be configured to run in full-power dual, long-life single, and automatic lamp relay modes. In automatic relay mode, lamps will alternate in operation to keep both lamps at the same performance level at all times. Lamp hours and usage is stored in the lamp, making performance checking easy in for instance rental applications.

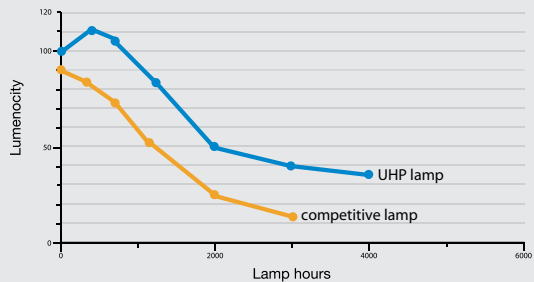

Long lamp life

Using Long life, 300W UHP™ lamps gives better performance than using comparable lamps from other manufacturers. As high power lamps often have shorter life time, the actual performance from a 300W is higher than that of the comparable lamp over most of its life time, and even lasts twice as long, even if the higher power lamp has a higher initial output. The 300W lamp even increases up to 10% in brightness over the first 100 hours.





projection design® F3+

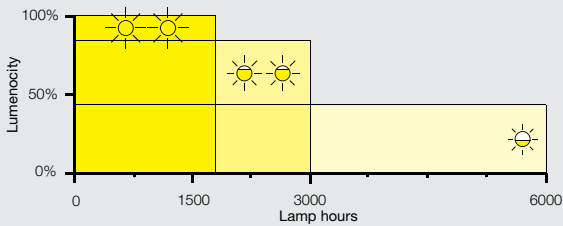

Failsafe dual lamp architecture

The patented DuArch™ architecture features two high performance 300W UHP™ lamps accessible from the side of the projector. This allows easy lamp replacement while mounted, and reduces down-time during for instance service inspections. Lamps can be individually replaced while the projector is in operation.

Adjustable output power and system matching

In order to match any number of projectors on exact brightness output, the user can adjust power output for each lamp individually, in addition to adjusting illumination lens aperture IRIS. This gives an infinitely adjustable brightness output from below 1000 lumens, to as high as 6500 ANSI lumens.

Custom colour wheel options

The F3+ features several different colour wheel options as standard, optimised for different applications. For visualisation and simulation, as well as photographic reproduction,

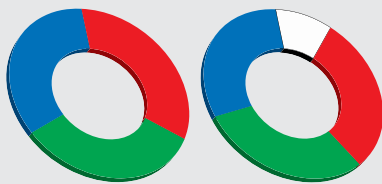

a 3-segment, 3x colour wheel increases colour gamut, and reduces colour break up artefacts. Two different 4-segment, 2x colour wheels are also available; one optimized for high brightness applications, the other for increased colour saturation and video performance. The F3+ XGA can be had with custom 6-segment, 4x colour wheels.

RealColor colour management

RealColor is a proprietary and highly accurate colour management system for projectors. It allows the user to correctly and easily calibrate and set up a projector to a desired white point and grey scale tracking with a minimum amount of effort. By characterizing every single projector in the factory, knowing it's electrical and optical properties, it provides tools for matching and calibrating any number of projectors in a single application.



High end video processing

For standard moving video processing, the F3+ features the highly regarded Faroudja® FLI2310 deinterlacing chipset. Compatible with both standard definition, and High definition analogue input sources, patented technologies such as 3:2 and 2:2 pull-down with bad edit detection, DCDi™ (Directional Correlational Deinterlacing), Cross-colour suppression and TrueLife™ non-linear enhancement combine to create superb results, converting standard interlaced video to high resolution progressive scan images - free from artefacts, and with sharp, detailed pictures with deeply saturated colours.



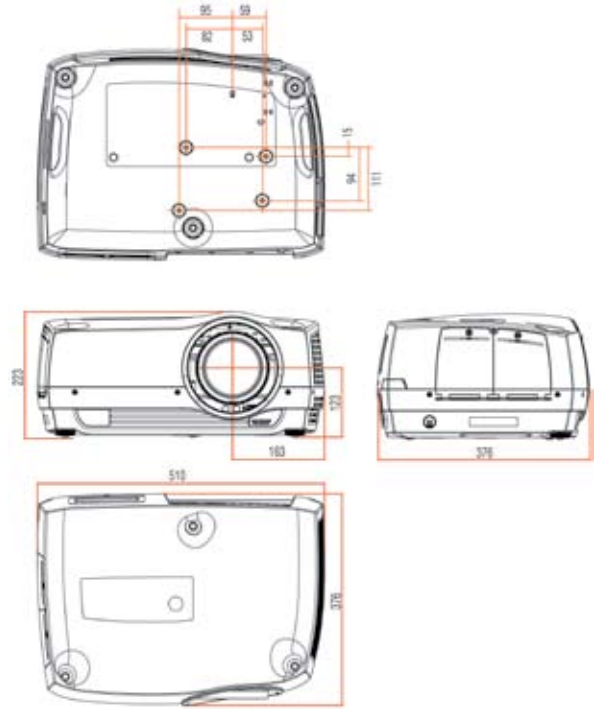

Designed for flexibility

The F3+ has been designed to be the ultimately flexible projector. User replaceable bayonet mount lenses, full lens shift both vertically and horizontally (110% and 90% respectively), full illumination control - no other projector is even close in image adjustability. From auditoriums and events needing high brightness, to smaller settings where resolution, picture quality, contrast and readability is more important. The F3+ can fit in to all installations.

Stacking of units

With the built-in lens shift possibilities, the F3+ can easily be stacked on top of each other for multiplying the light output, or to provide simple and quick set up for passive stereo configurations. The cabinet has simple, non-locking stacking features to allow this without any further equipment or mounts. Units can also be stacked side by side in order to facilitate this.

Wide range of lenses

Six easily replaceable bayonet mount lenses cover every need. From the Ultra Wide Angle at 0.8 : 1, designed for rear projection, to the Super Tele Zoom at 5.5 - 9.6 : 1 ratio. All lenses, with the exception of the Ultra Wide Angle - designed for on-axis projection, feature full lens shift.

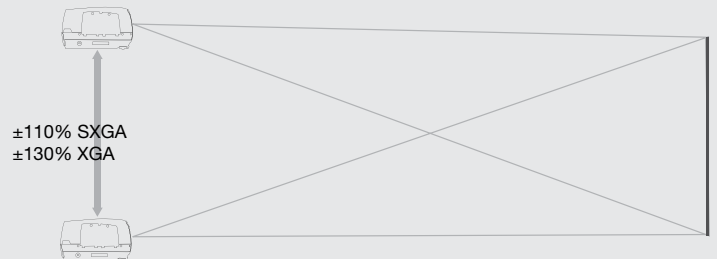

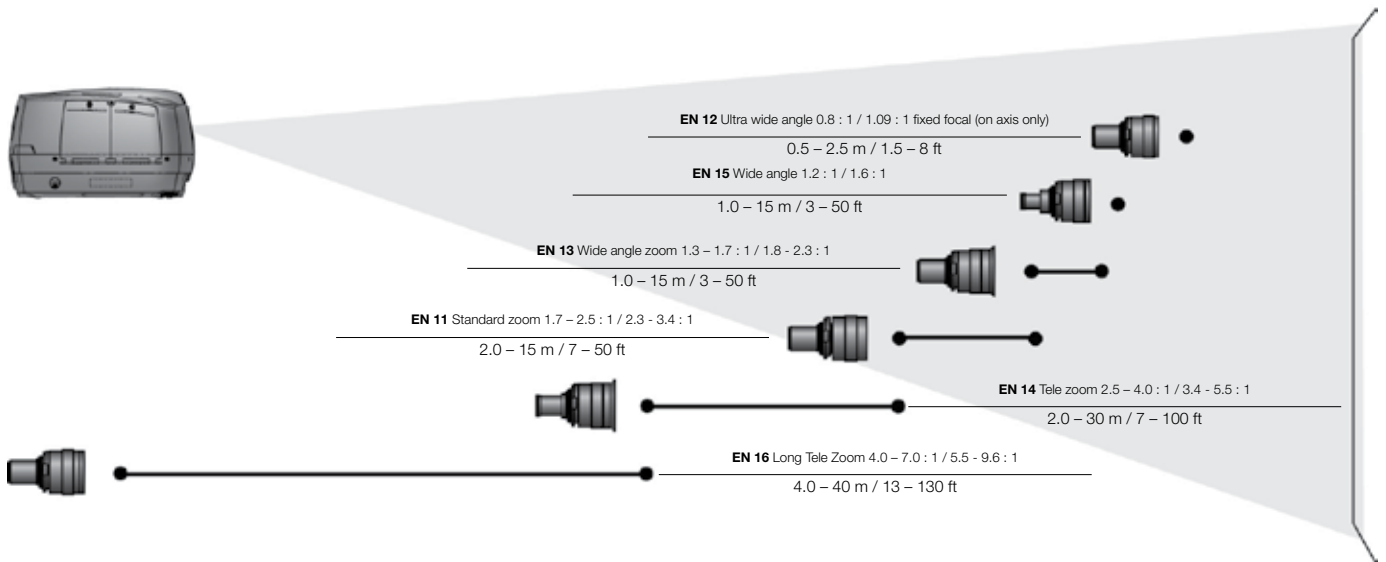

Control and command

The F3+ features direct RS232 and RS232 bus connectivity, with up to 128 devices connected to the same control console. It also features a dedicated TCP/IP interface, with a built in web page, and can be used with any type of system controller. For simpler set-ups, the backlit IR remote control features wired connection and individual ID settings, so it can be used to control a number of units individually, changing the ID of which one it controls at the click of a button.

Remote asset management

The F3+ supports remote asset management through RS232 and TCP/IP. All status- and operating information can be retrieved in order for a systems controller to operate and manage projectors from a central location.



Status monitoring

In order to secure functionality and up-time, the F3+ features a wide range of status monitoring features. The large, backlit LCD display on the rear displays all status information, from current source, to lamp status, operating hours, and all possible settings. There is also an incredibly useful and 100% failsafe visual inspection of lamps, so one can monitor which lamp is running, and in what mode the projector operates. Remotely, all status information can be retrieved over the dedicated TCP/IP connection, as well as over RS232.

PIN code locking function

A familiar Personal Identification Number (PIN) code system can be used to completely lock the projector for unwanted use or as anti-theft precaution. A 4-digit code can be created and individually configured.

SOA – Sealed Optical Architecture

To ensure faultless and trouble-free operation in unforgiving and harsh environments, the F3+ features a fully sealed optical architecture. Dust, smoke and other tiny particles are prevented from entering and contaminating the delicate light engine, thus will not alter the displayed image over time. In addition, it ensures the projector requires almost no servicing and maintenance.



Expandable input section*

In addition to all common interfaces, such as HDCP compatible DVI, BNC and VGA connectors, the F3+ is totally unique in the way it offers the user to specify expansion options through our XPort™ technology. By granting access to the internal signal processing architecture, both front- and back end, users can develop and attach any type of signal processing unit. Front end options include SDI / HD-SDI and for instance IEEE1394 video interfaces, back end processing can include geometry correction boards, or blending and shading expansions.

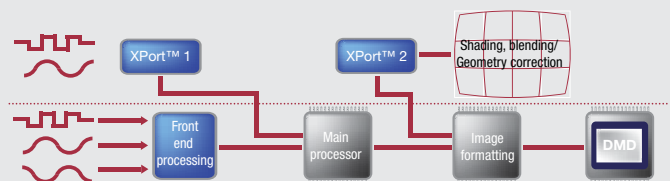

* Requires license agreement with projectiondesign.

Technical Specifications

		F3+ SX+	F3+ XGA
Projector		SXGA+ DLP™ digital projector	XGA DLP™ digital projector
Display	Technology	Single chip LVDS DLP™ technology with DarkChip3™	Single chip LVDS DLP™ technology with DarkChip3™
	Concept	Sealed, all-glass, optical design	Sealed, all-glass, optical design
	Resolution	1400 x 1050 SXGA+ pixel resolution	1024 x 768 XGA pixel resolution
	Brightness	Variable; 6500 ANSI lumens (max) - 1000 ANSI lumens (min)	Variable; 5500 ANSI lumens (max) - 1000 ANSI lumens (min)
	Contrast (on/ off)	Variable; 7500 : 1 (max) - 1200 : 1 (min)	Variable; 7500 : 1 (max) - 1200 : 1 (min)
	Aspect Ratio	4 : 3 native, 5 : 4 and 16 : 9 compatible	4 : 3 native, 5 : 4 and 16 : 9 compatible
	Colours	16.8 Million displayable	16.8 Million displayable
	Image Processing Latency	~ 1 input frame with graphics	~ 1 input frame with graphics
Compatibility	Computer Compatibility	UXGA, SXGA+, SXGA, XGA, SVGA, VGA, RGBHV, RGBS, RGsB	UXGA, SXGA+, SXGA, XGA, SVGA, VGA, RGBHV, RGBS, RGsB
	Horizontal Scan	15 - 150 kHz	15 - 150 kHz
	Vertical Scan	48 - 190 Hz	48 - 190 Hz
	Video Compatibility	HDTV (1080i, 720p, 576i/p, 480i/p) NTSC, NTSC4.43, PAL, PAL-M, PAL-N, SECAM	HDTV (1080i, 720p, 576i/p, 480i/p) NTSC, NTSC4.43, PAL, PAL-M, PAL-N, SECAM
	Bandwidth	205 MHz on analog RGB, 165 MHz on digital RGB over DVI	205 MHz on analog RGB, 165 MHz on digital RGB over DVI
Lenses		EN 12 503-0057-00 Ultra Wide Angle Lens 0.8 : 1 (on axis only) EN 15 503-0060-00 Wide Angle Lens 1.2 : 1 (on or off axis) EN 13 503-0058-00 Wide Angle Zoom Lens 1.3 - 1.7 : 1 (on or off axis) EN 11 503-0056-00 Standard Zoom Lens 1.7 - 2.5 : 1 (on or off axis) EN 14 503-0059-00 Tele Zoom Lens 2.5 - 4.0 : 1 (on or off axis) EN 16 503-0061-00 Super Tele Zoom Lens 4.0 - 7.0 : 1 (on or off axis)	Ultra Wide Angle Lens 1.09 : 1 (on axis only) Wide Angle Lens 1.6 : 1 (on or off axis) Wide Angle Zoom Lens 1.8 - 2.3 : 1 (on or off axis) Standard Zoom Lens 2.3 - 3.4 : 1 (on or off axis) Tele Zoom Lens 3.4 - 5.5 : 1 (on or off axis) Super Tele Zoom Lens 5.5 - 9.6 : 1 (on or off axis)
	Lens Operation	Motorized zoom/focus/shift for all lenses	Motorized zoom/focus/shift for all lenses
	IRIS control	Motorized IRIS control for F/2.1 - 6.1 for all lenses	Motorized IRIS control for F/2.1 - 6.1 for all lenses
Optics	Lens Shift	+/- 110% vertical, +/- 90% horizontal	+/- 130% vertical, +/- 110% horizontal
	Lamp	300W UHP™ x2	300W UHP™ x2
	Lamp Power Control	250 - 300W in 5W increments	250 - 300W in 5W increments
	Lamp Life	6000 hours (max), 1700 hours (min) (at full eco mode and full power mode respectively)	6000 hours (max), 1700 hours (min) (at full eco mode and full power mode respectively)
	Colour Wheel Options	3-segment 3x graphics, visualisation and simulation 4-segment 2x graphics 4-segment 2x high brightness	6-segment 4x graphics, visualisation and simulation 4-segment 2x graphics 4-segment 2x high brightness
	Shutter	Mechanical	Mechanical
Inputs / Outputs	Computer Inputs	1x 15 pin HDDSUB (analog RGB) 1x DVI-D	1x 15 pin HDDSUB (analog RGB) 1x DVI-D
	Video Inputs	1x BNC x5 (analog RGBHV) 1x RCA x3 (component) x 4-pin Mini DIN (S-video) 1x RCA (video)	1x BNC x5 (analog RGBHV) 1x RCA x3 (component) x 4-pin Mini DIN (S-video) 1x RCA (video)
	Other Inputs	2x XPort (1x front end, 1x back end)	2x XPort (1x front end, 1x back end)
	Control and Communication	2x 12V/60mA Trigger (screen, aspect) 2x RS232 9-pin DSUB (control) in/out (male/female) 1x RJ45 TCP/IP network port Remote control infrared and wired	2x 12V/60mA Trigger (screen, aspect) 2x RS232 9-pin DSUB (control) in/out (male/female) 1x RJ45 TCP/IP network port Remote control infrared and wired
	Computer Output	1x USB (mouse control and firmware upgrade) 1x 15 pin HDDSUB (analog) monitor	1x USB (mouse control and firmware upgrade) 1x 15 pin HDDSUB (analog) monitor
Supplied Accessories	Cables	4 m power cord	4 m power cord
	Other	Ceiling Mount Cable Cover Standard IR remote control	Ceiling Mount Cable Cover Standard IR remote control
General	Operating Noise Level(typ)	30 dB (A) at 20C/ 68F, sea level	30 dB (A) at 20C/ 68F, sea level
	Dimensions (dwh)	376 x 510 x 223 mm / 14.8 x 20.0 x 8.8 in	376 x 510 x 223 mm / 14.8 x 20.0 x 8.8 in
	Weight	12.6 kg/27.8 lbs + lens (1.9 kg/4.2 lbs to 2.6 kg/5.5 lbs).	12.6 kg/27.8 lbs + lens (1.9 kg/4.2 lbs to 2.6 kg/5.5 lbs).
	Power Requirements	90 - 260 VAC, 50/60 Hz 1050 W power consumption	90 - 260 VAC, 50/60 Hz 1050 W power consumption
	Conformances	CE, FCC Class A, CSA (C/US), CCC	CE, FCC Class A, CSA (C/US), CCC
	Operating Temperature	0-40C/32-104F, 0-1500m 0-35C/32-95F, 1500-3000m	0-40C/32-104F, 0-1500m 0-35C/32-95F, 1500-3000m
	Operating Humidity	20 -90% RH	20 -90% RH
	Storage Conditions	20 - 90% RH	20 - 90% RH
	Colours	Black metallic, Silver metallic	Black metallic, Silver metallic
	Warranties	2 years, 500 hours or 90 days on lamp optional 3rd year warranty	2 years, 500 hours or 90 days on lamp optional 3rd year warranty



Designed and manufactured in Norway by:
 projectiondesign as
 Habornveien 53
 N-1630 Gamle Fredrikstad
 Norway
 +47 69 30 45 50

Distributed by:



sales@projectiondesign.com
 www.projectiondesign.com